

Effect of Parameter Tuning on Performance of Cuckoo Search Algorithm for Optimal Reactive Power Dispatch

Tejaswini Sharma

Department of Electrical Engineering
Madhav Institute of Technology & Science
Gwalior, India

sharmatejaswini2206@gmail.com

Laxmi Srivastava

Department of Electrical Engineering
Madhav Institute of Technology & Science
Gwalior, India

srivastaval@hotmail.com

Abstract

This paper presents an effective optimization algorithm to solve the optimal reactive power dispatch (ORPD) problem. Cuckoo search (CS) algorithm is a recently invented reliable optimization technique for obtaining near global optimization. The CS was inspired by the obligate brood parasitism of some cuckoo species by laying their eggs in the nests of host birds. In cuckoo search optimization algorithm, parameter tuning is very important for finding the solution. In this paper, optimal reactive power dispatch is carried out for reducing real power losses in a power system. The ORPD problem has been solved as the single objective nonlinear constrained optimization problem with equality and inequality constraints for minimization of power losses. The control variables for ORPD problem considered are the generators voltage and transformers tap settings. Effect of various parameters on the performance of CS algorithm has been analyzed by applying it for ORPD problem in the standard IEEE 30-bus test system.

Keywords—optimal reactive power dispatch problem, cuckoo search algorithm, real power loss.

I. INTRODUCTION

In a power system, reactive power and voltage control play an important role in improving the security and the economics of power systems. Reactive power / voltage control is very important for proper operation of power system [1]. Optimal reactive power dispatch (ORPD) is required for reducing losses in transmission lines. It also improves the voltage profile and voltage stability in a power system. Power system operator can set various control variables such as generator voltage magnitude, transformer tap setting and switchable VAR sources [3, 9].

Over the past decades, several conventional approaches have been applied for solving optimal reactive power dispatch problem in power system. Conventional optimization techniques such as interior point method (IPM), nonlinear programming (NLP), linear programming (LP), gradient method (GM), mixed integer programming (MIP), quadratic programming (QP) etc. have been used for solving ORPD problem.

All the conventional optimization methods fail in case of non-differential, non-linear, multi-modal characteristic, non-smoothness and non-convex nature of the problem [7]. Recently, numerous evolutionary algorithms such as Genetic Algorithm (GA), Differential Evolution (DE), Simulated Annealing (SA), Adaptive Hopfield Neural Network, Evolutionary programming (EP), Evolutionary strategies (ES), and Particle Swarm Optimization (PSO) etc. are applied to solve optimal reactive power dispatch problem [2].

Reactive power dispatch provides the power system operator a set of control variables to reduce power losses and to reserve bus voltage magnitude within the allowable limit by rearrangement of the power flows [9, 10]. In the present paper, the main objective of optimal reactive power dispatch is to reduce real power losses in transmission lines of a power system.

This aim is accomplished by the proper setting of control variables such as generators voltage magnitude and transformers tap settings, which are obtained by applying cuckoo search algorithm. Cuckoo search algorithm is a relatively new search algorithm, which is motivated by the lifestyle of cuckoo bird [6].

II. PROBLEM FORMULATION

The objective function of ORPD is to minimize real power loss (P_{loss}) in transmission lines of a power system while satisfy all operating constraints. This is mathematically stated as follows [4].

A. Objective function

1) Real Power Loss Minimization

The minimization of system real power losses P_{loss} can be calculated as follows:

$$f = p_{loss} = \sum_{i,j=1}^{n_l} g_k [v_i^2 + v_j^2 - 2v_i v_j \cos(\delta_i - \delta_j)]$$

(1) Where

nl is the number of transmission lines; gk is the conductance of the k_{th} line;

V_i, V_j is the voltage magnitude at the end buses i and j of k_{th} line, respectively;

δ_i, δ_j is the voltage phase angle at the end buses i and j .

B. System constraints

1) Equality constraints

These constraints represent load flow equations:

$$P_{Gi} - P_{Di} - V_i \sum_{j=1}^{NB} V_j [G_{ij} \cos(\delta_i - \delta_j) + B_{ij} \sin(\delta_i - \delta_j)] = 0 \quad (2)$$

$$Q_{Gi} - Q_{Di} - V_i \sum_{j=1}^{NB} V_j [G_{ij} \sin(\delta_i - \delta_j) - B_{ij} \cos(\delta_i - \delta_j)] = 0 \quad (3)$$

$$Q_{Gi} - Q_{Di} - V_i \sum_{j=1}^{NB} V_j [G_{ij} \sin(\delta_i - \delta_j) - B_{ij} \cos(\delta_i - \delta_j)] = 0 \quad (4)$$

Where $i=1 \dots NB$;

NB is the number of buses;

P_G is the active power generated;

Q_G is the reactive power

generated; P_D is the load active power;

Q_D is the load reactive power;

G_{ij}, B_{ij} is the transfer conductance and susceptance between bus i and bus j , respectively.

2) Inequality constraints

These constraints include:

a) Generator constraints: Generator voltages and reactive power outputs are restricted by their lower and upper limits as follows:

$$V_{Gi}^{min} \leq V_{Gi} \leq V_{Gi}^{max}, \quad i = 1, \dots, NG \quad (5)$$

$$Q_{Gi}^{min} \leq Q_{Gi} \leq Q_{Gi}^{max}, \quad i = 1, \dots, NG \quad (6)$$

b) Transformer constraints: transformer tap settings are bounded as follows:

$$T_i^{min} \leq T_i \leq T_i^{max}, \quad i = 1, \dots, NT \quad (7)$$

c) Shunt VAR constraints: shunt VAR compensations are bounded by their limits as follows:

$$Q_{Ci}^{min} \leq Q_{Ci} \leq Q_{Ci}^{max}, \quad i = 1, \dots, Nc \quad (8)$$

d) Security constraints: these include the constraints of voltages at load buses and transmission line loadings as follows:

$$V_i^{min} < V_i < V_i^{max}, \quad i = 1, \dots, NL \quad (9)$$

$$S_{ij} \leq S_{ij}^{max}, \quad i = 1, \dots, NI \quad (10)$$

III. CUCKOO SEARCH ALGORITHM

A. An Overview

Cuckoo birds attract attention of many scientists around

the world because of their unique behavior. They have many characteristics which differentiate them from other birds, but their main unique feature is aggressive reproduction strategy. Cuckoo search (CS) is an optimization algorithm developed by Xin-she Yang and Suash Deb in 2009. The CS optimization algorithm was inspired by the obligate brood parasitism of some cuckoo species by laying their eggs in the nests of host birds. Some cuckoos have developed in such a way that female parasitic cuckoos can duplicate the colors and patterns of the eggs of a few chosen host species [6].

This reduces the probability of the eggs being unrestricted and, therefore, raises their reproductivity. It is worth revealing that numerous host birds engage direct conflict with intruding cuckoos. In this case, if other host birds discover the eggs are not their own, they will either throw them away or abandon their nests and build new ones, elsewhere [5]. In Cuckoo search optimization algorithm, each egg in a nest characterizes a solution, and a cuckoo egg characterizes a new solution in a nest [6].

The aim in CS algorithm is to employ the new and possibly better solutions to replace not-so-good solutions in the nests. The flowchart of CS algorithm has been shown in figure 1 [5]. In the simple form, each nest has only one egg. The algorithm can be extended to more complex cases in which each nest has multiple eggs representing a set of solutions [6]. The CS algorithm is based on the following three ideal rules:

- Each cuckoo lays one egg at a time, and dumps it in a randomly chosen nest;
- The best nests with high quality of eggs (solutions) will carry over to the next generations;
- The number of accessible host nests is

fixed, and a host can discover an unfamiliar egg with probability
 $pa \in [0, 1]$ (11)

Algorithm1. Cuckoo Search [6]

Start
 Objective function $f(x)$, $x = (x_1, x_2, \dots, x_m)^T$;
 Initialize a population of n host nests x_i ($i = 1, 2, \dots$
 n); While ($t < \text{Max Generation}$) or (stop condition);
 Generate a cuckoo randomly by Lévy flights;
 Evaluate its fitness F_i ;
 Randomly choose a nest among n (say j)
 available nests;
 If ($F_i > F_j$), Substitute j by the new
 solution; End
 Abandon a fraction (pa) of worst nests and build
 new nest at new locations via Lévy flight;
 Keep the best solutions (or nests with
 quality solutions);
 Rank the solutions and find the recent best
 solution; End while
 Post process results and visualization;
 End

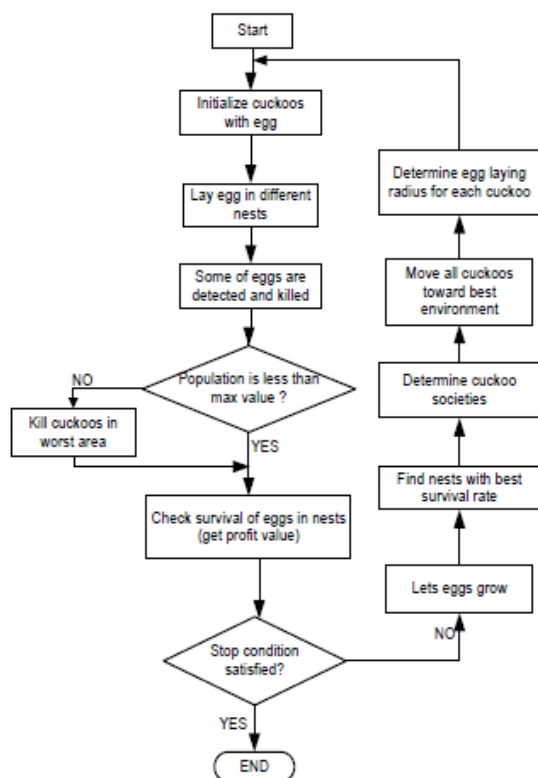

Fig. 1. Flowchart of Cuckoo Search Optimization

IV. RESULT AND DISCUSSION

The proposed method has been tested on standard IEEE 30 bus test system. IEEE 30 bus test system has 6 generator buses and 4 tap setting transformer, 24 load buses, and 41 transmission line which 4 branch (6-9), (6-10), (4-12), and (28-27) is shown in figure 2. CS algorithm is applied for real power loss reduction in this test system. This has been observed that the performance of CS algorithm is mainly affected by two parameters namely, number of nests and number of generation. To obtain the best performance of CS algorithm, appropriate values of these parameters or parameter tuning is a must. An optimum value of these parameters has been obtained by having various trials by changing one parameter at a time and keeping the other one fixed.

A. Number of nests for constant generation = 100

In this case, the effect of number of nest on the performance of CS algorithm has been determined. The number of nests has been taken as 10, 20, 50, 80, 100, 120, 150, 180, 200 and 220 and its effect on the performance of CS algorithm is investigated. Here, the number of generation is set to 100 and the effect of number of nest on the performance of CS algorithm is shown in Table 1 and figure 3. The proposed Cuckoo Search algorithm is run for minimization of real power losses.

As can be observed from Table 1 and figure 3, the best result is obtained when number of nest was 200. In this case, the CS algorithm provides the minimum real power loss of 4.84380 MW as shown in Table 1. The control variables namely voltage magnitudes at 6 generators and tap settings of 4 transformers are shown in Table 2. The convergence characteristic of CS algorithm with number of nest 200 for P_{loss} minimization is shown in figure 4.

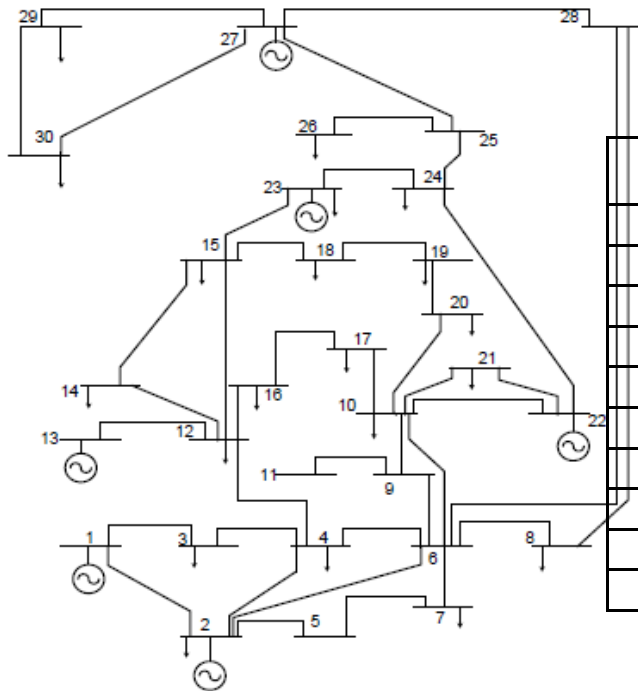

Fig.2. Single Line Diagram of IEEE 30-bus System

TABLE 1. NUMBER OF NESTS FOR CONSTANT GENERATION = 100

S. No	No. of Nest	No. of Generation	Power Loss	Elapsed Time
1	10	100	6.0479	0.183545
2	20	100	5.3955	0.161704
3	50	100	5.2468	0.146331
4	80	100	4.9840	0.162077
5	100	100	4.9426	0.175907
6	120	100	5.1701	0.205297
7	150	100	4.9522	0.235023
8	180	100	5.0109	0.273605
9	200	100	4.8438	0.344952
10	220	100	4.9055	0.350297

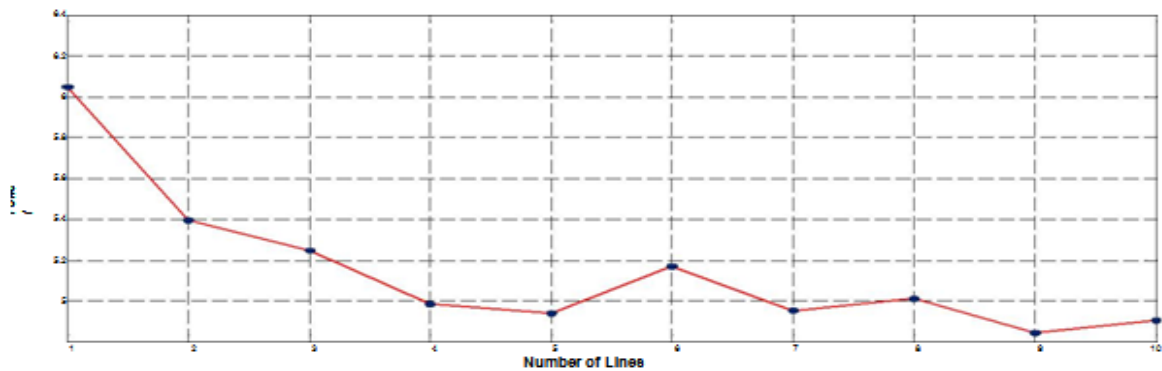

Fig. 3. Convergence Characteristic for Ploss A

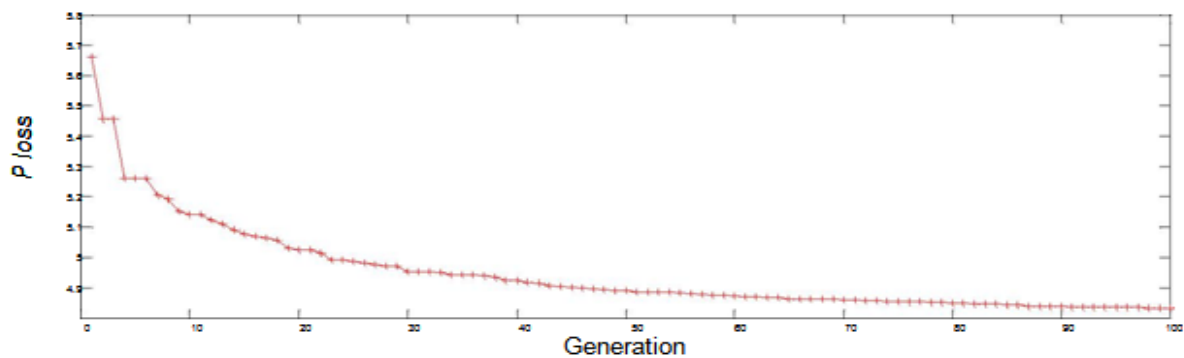

Fig. 4. Convergence Characteristic for Power Loss Minimization

TABLE 2. SETTING OF CONTROL VARIABLE FOR LOSS MINIMIZATION

S. NO.	Control variable	CS
1	V1	1.0997
2	V2	1.0917
3	V5	1.0715
4	V8	1.0719
5	V11	1.0973
6	V13	1.0990
7	T11	1.0684
8	T12	0.9036
9	T15	1.0521
10	T36	0.9859
Power Loss (MW)		4.84380

B. Number of generation for constant number of nest = 200

In this case, the effect of number of generation on the performance of CS algorithm has been investigated. The number of generation has been taken as 50, 100, 150, 200, 250, 300, 350, 400 and 450 and its effect on the performance of CS algorithm is investigated. Here, the number of nest is set to 200 and the effect of number of generation on the performance of CS algorithm is shown in Table 3 and figure 5. The proposed Cuckoo Search algorithm is run for minimization of real power losses. As can be observed from Table 3 and figure 5, the best result is obtained when number of generation was 400. The CS algorithm provides the minimum real power loss of 4.8534MW as shown in Table 3.

The control variables namely voltage magnitudes at 6 generators and tap settings of 4 transformers are shown in Table 4. The convergence characteristic of CS algorithm with number of generation 400 for P_{loss} minimization is shown in figure 6. This can be clearly observed from above investigation that the best performance of CS algorithm has been obtained with number of nest is 200 and number of generation 400 when applied for power loss minimization in IEEE 30-bus system.

TABLE3. NUMBER OF GENERATION FOR CONSTANT NUMBER OF NEST = 200

S. No	No of Nest	No. of Generation	Power Loss	Elapsed Time
1	200	50	4.9820	0.407935
2	200	100	4.9170	0.336659
3	200	150	4.8415	0.149761
4	200	200	4.8535	0.176788
5	200	250	4.8863	0.168110
6	200	300	4.8855	0.176145
7	200	350	4.8575	0.132176
8	200	400	4.8534	0.104665
9	200	450	4.8534	0.108820

TABLE 4. SETTING OF CONTROL VARIABLE FOR LOSS MINIMIZATION

S. No.	Control Variable	CS
1	V1	1.0969
2	V2	1.0901
3	V5	1.0686
4	V8	1.0694
5	V11	1.0999
6	V13	1.0999
7	T11	1.0272
8	T12	0.9362
9	T15	1.0604
10	T36	0.9825
Power Loss (MW)		4.85340

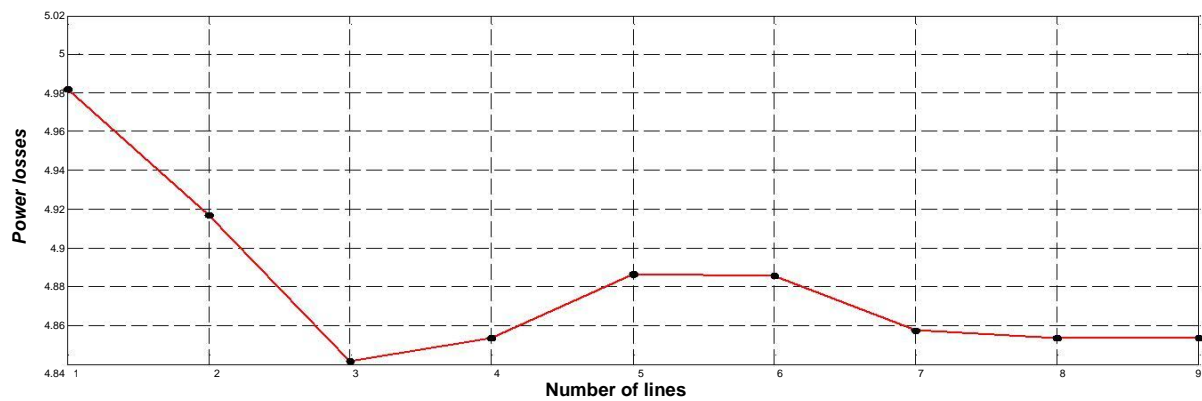

Fig. 5. Convergence Characteristic for Ploss B

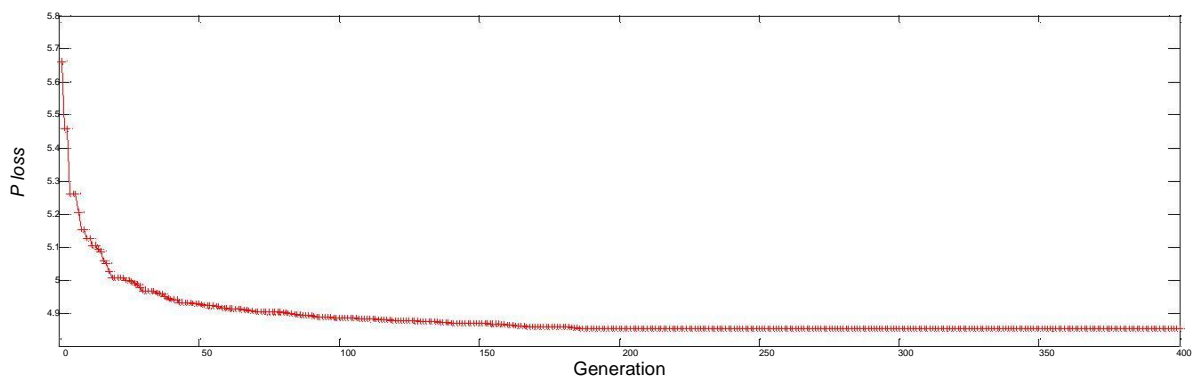

Fig. 6. Convergence Characteristic for Power Loss Minimization

V. CONCLUSION

In this paper, cuckoo search optimization algorithm has been proposed for reduction of real power losses. Like other population based optimization algorithms, the performance of CS algorithm is greatly affected by its parameters and hence to obtain the best performance of CS algorithm, appropriate values of these parameters or parameter tuning is a must. In this paper, optimum value of these parameters has been obtained by having various trials by changing one parameter at a time and keeping the other one fixed. Effectiveness of the proposed approach has been demonstrated on IEEE 30- bus system. This paper shows that best performance of the proposed CS algorithm can be obtained with proper parameter tuning. As the CS algorithm based approach is quite fast and provides near global optimized solution, it can be applied for practical power system as well.

ACKNOWLEDGMENT

The authors sincerely acknowledge the financial support provided by University Grants Commission (UGC), New Delhi, India under Major Research Project received vide F. No. 41-657/2012[SR] dated 26-07-2012 and the Director, MITS Gwalior, India to carry out this work.

REFERENCES

- [1] Congyu Zhang, Minyou Chen and Ciyong Luo, "A Multi-objective Optimization Method for Power System Reactive Power Dispatch", *in proceedings of the Intelligent Control and Automation 28th World Congress*, pp. 6-10, (2010).
- [2] Guanglin Cai, Zhen Ren and Tao Yu, "Optimal Reactive Power Dispatch Based on Modified Particle Swarm Optimization Considering Voltage Stability", *in proceedings of the Power Engineering Society General Meeting, IEEE*, pp. 1-5, (2007).
- [3] D. Godwin Immanue and Dr. C. Chritober Asir Rajan, "A Multi Objective Genetic Algorithm approach to Reactive Power and Voltage Control in Power System", *International Journal of Research in Engineering and Technology*, vol. 2, pp. 174-178, (2013).
- [4] A.A. Abou El Ela, M.A. Abido, S.R. Spea "Differential evolution algorithm for optimal reactive power dispatch", *International Journal of Electric Power Systems Research*, vol. 30, pp. 435-441, (2008).
- [5] Ehsan Valian, Shahram Mohanna and Saeed Tavakoli, "Improved Cuckoo Search Algorithm for Global Optimization", *International Journal of Communications and Information Technology*, vol.1, pp. 31-44, (2011).
- [6] Yang, X.-S., and Deb, S., "Engineering Optimisation by Cuckoo Search", *Int. J. Mathematical Modelling and Numerical Optimisation*, vol.1, pp.330-343, (2010).
- [7] Himmat Singh, L. Srivastava, "Multi-objective Reactive Power Management using Differential Evolution", *International conference IICPE-2012, held at New Delhi india*, 6-8 Dec. 2012.
- [8] Tejaswini Sharma, "Optimal Reactive Power Dispatch for Loss Reduction and Improvement of Voltage Profile Using Cuckoo Search Algorithm", *Journal of Innovative trends in Science, Pharmacy & Technology*, vol. 1, pp. 18-22, jan. 2014.
- [9] Himmat Singh, L. Srivastava, "Modified Differential Evolution Algorithm for Multi Objective VAR Management", *International Journal of Electric Power and Energy Systems*, vol. 55, pp.731-740, (2014).
- [10] Anuradha Bhadouria, Dr. Laxmi Srivastava, "Optimal Reactive Power Dispatch Using The Matlab Optimization Toolbox", *IJAIR*, vol. 2, pp.161-166, 2013.